

YIELD CONDITIONS FOR LAYERED COMPOSITES

ANDRZEJ SAWICKI

Polish Academy of Sciences; Institute of Hydroengineering, Gdańsk-Oliwa,
Poland

(Received 2 October 1980; in revised form 19 January 1981)

Abstract—The continuum elasto-plastic theory of layered composites is presented. The composite consists of two elasto-ideal plastic constituents. The associated flow rule is assumed to be valid for both constituents. The starting point of the presented considerations is an elastic state described by structural relations, i.e. relations between microstresses (-strains) and macrostresses (-strains). The behaviour of the composite in the case when one of the constituents becomes plastic, as well as the global yield conditions are investigated. The presented theory is illustrated by numerous examples for the case when both constituents obey the Huber-Mises yield condition, and for particular stress states and loading paths.

1. INTRODUCTION

The aim of the paper is to present the continuum theory of layered composites consisting of two elasto-ideal plastic constituents. If such material is considered in respectively large scale, i.e. if characteristic dimension of nonhomogeneity is small in comparison to the characteristic dimension of the solid, it can be regarded macroscopically like a homogeneous and anisotropic one.

One of the fundamental problems appearing in the theory of composites is the description of the macroscopic behaviour of the material knowing mechanical properties of the constituents and the internal geometry of the composite.

There are two basic approaches in the theory of composites. One of them distinguishes the discrete structure of the composite, the second approach is a continuum one. The continuum approach is very useful in an engineering practice because it allows to solve analytically boundary value problems. Rather simple situation exists in the case when both constituents of the composite are assumed to work in an elastic range. There exist some representative theories making possible a simple analysis of the material.

The very useful approach allowing to study analytically statical problems is the effective moduli theory, the final product of which are constitutive equations describing the macroscopic behaviour of the composite. These equations are in the form of those for the anisotropic materials. Here, one can mention the papers of Postma[1], Hashin and Rosen[2], Salamon[3] and the author[4]. The effective moduli theory is not sufficient for describing the dynamic behaviour of the composite, because the effect of microstructure is essential in this case. Then, the more advanced theories have been developed, see for example the papers of Sun *et al.*[5], Hegemier *et al.*[6], Stern and Bedford[7], Hlaváček[8].

If the detailed geometry of the composite is unknown or if it is not taken into account, the variational theorems can be applied allowing to obtain the upper and lower bounds of the elastic moduli of the composite obtained in terms of phase properties and volumetric participations. This problem is discussed in the papers of Hashin and Shtrikman[9, 10], Hill[11].

Much more complicated situation appears in the plasticity theory of composites. There do not exist sufficiently general approaches in this field, although more and more papers are published. The majority of existing papers deal with the plasticity of the fibre-reinforced composites.

An elementary approach is presented in the paper of Prager[12], where failure of the matrix of a fibre-reinforced composite sheet is studied. The matrix is treated as the Huber-Mises, perfectly plastic material. The fibres are regarded as constraints imposed on strain rates in respective directions. The similar approach is presented in the author's paper[13], where the rigid-plastic model of reinforced earth is discussed. In this paper the soil is assumed to obey the Coulomb-Mohr yield condition. Also, the paper of Lance and Robinson[14] may be grouped together with the above quoted two papers. The authors consider the Tresca material reinforced by stiff fibres and analyse particular forms of composite failure.

The composite consisting of elastic-perfectly plastic fibres arranged in a strengthless matrix is considered by McLaughlin and Batterman[15]. In the paper of McLaughlin[16] the matrix contribution to the composite strength is taken into account. One can also mention the paper of Mulhern *et al.*[17] dealing with the elasto-plastic matrix reinforced by strong elastic fibres, and the papers of Kafka[18–20].

From the above, very short, review of some existing papers dealing with the plasticity of fibre-reinforced composites the variety of approaches is visible. Every approach is adjusted to a particular problem (or a certain class of problems) and takes into account the main features of composite behaviour, essential in this case. There do not exist general theories, however some papers may be treated as ones of general character, e.g. the paper of Hill[21], where the very important problem of the existence of the composite yield surface is discussed.

The starting point of another approach to the plasticity of composites is plasticity theory of anisotropic solids, based for example on the representation theorems for tensor functions[22]. This approach is of the “black box” type. The experiment plays here the fundamental role and allows to obtain the values of parameters describing the composite behaviour.

The author has proposed the continuum, elasto-plastic theory of composites with regular internal structure. The basic concepts of this theory are presented in [23, 24]. The present paper is devoted to the application and development of the theory proposed in [23] to the layered composites. In the author's belief the plasticity of layered composites forms a background for technically more important problems of fibre-reinforced composites.

2. BASIC RELATIONS

2.1. Assumptions

The considered composite consists of two continuous, elastic-ideal plastic constituents. The associated flow rule is assumed to be valid for both constituents. The geometry of the composite is schematically presented in Fig. 1, where the coordinate axes are also marked. These axes are anisotropy ones for macroscopic description of the composite behaviour. It is also assumed that in every point of the composite both components exist simultaneously. This assumption is characteristic for mixture theories and it is often used in continuum theories of composites.

The element of the composite, schematically presented in Fig. 1, is called “representative elementary volume” and it is occupied by both constituents. The following relation appears:

$$\eta_1 + \eta_2 = 1, \quad (2.1)$$

where η_i denotes the volumetric participation of the i -th component in the composite.

Following the above assumptions, the three stress and strain tensors are defined in every point of the composite, such that:

$$\sigma = \eta_1 \sigma^{(1)} + \eta_2 \sigma^{(2)}, \quad (2.2)$$

$$\epsilon = \eta_1 \epsilon^{(1)} + \eta_2 \epsilon^{(2)}, \quad (2.3)$$

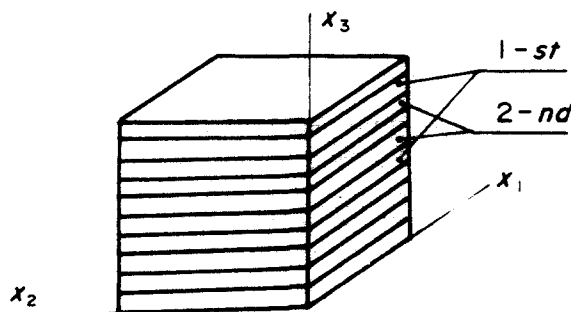

Fig. 1.

where $\sigma^{(i)}$ and $\epsilon^{(i)}$ are related to the i -th component and they are called the microstress and microstrain tensors respectively. σ and ϵ are called the macrostress and macrostrain tensors, and may be interpreted as the averages over the elementary volume. It is clear that the introduced quantities present the simplification of the real physical situation.

2.2. Elastic behaviour

The following linear relations are accepted after Hill [25], for the elastic range of composite behaviour:

$$\epsilon^{(i)} = \mathbf{A}^{(i)} \epsilon, \quad (2.4)$$

$$\sigma^{(i)} = \mathbf{B}^{(i)} \sigma, \quad i = 1, 2. \quad (2.5)$$

Further, the matrix notation will be used, such that:

$$\sigma = (\sigma_{11}, \sigma_{22}, \sigma_{33}, \sigma_{12}, \sigma_{13}, \sigma_{23})^T, \text{ etc.} \quad (2.6)$$

then, the quantities $\mathbf{A}^{(i)}$ and $\mathbf{B}^{(i)}$ are matrices. Relations (2.4) and (2.5) will be called the structural relations, respectively for strains and stresses and $\mathbf{A}^{(i)}$, $\mathbf{B}^{(i)}$ will be called the structural matrices.

For the elastic range of composite behaviour the constituents are assumed to be the linear Hookean bodies:

$$\sigma^{(i)} = \mathbf{L}^{(i)} \epsilon^{(i)}, \quad (2.7)$$

where $\mathbf{L}^{(i)}$ is the matrix of elastic moduli for the i -th component. From relations (2.2), (2.4) and (2.7) it follows:

$$\sigma = (\eta_1 \mathbf{L}^{(1)} \mathbf{A}^{(1)} + \eta_2 \mathbf{L}^{(2)} \mathbf{A}^{(2)}) \epsilon = \mathbf{L} \epsilon, \quad (2.8)$$

where \mathbf{L} is the matrix of "effective elastic moduli" for the composite. This matrix depends on the internal geometry of the composite and on elastic moduli of the constituents. The detailed derivation of quantities \mathbf{L} , $\mathbf{A}^{(i)}$, $\mathbf{B}^{(i)}$ for layered composite is presented in [4] and below only the final form of the structural matrices for stresses is presented:

$$\mathbf{B}^{(i)} = \begin{bmatrix} b_1^{(i)} & b_2^{(i)} & b_3^{(i)} & 0 & 0 & 0 \\ b_2^{(i)} & b_1^{(i)} & b_3^{(i)} & 0 & 0 & 0 \\ 0 & 0 & 1 & 0 & 0 & 0 \\ 0 & 0 & 0 & b_4^{(i)} & 0 & 0 \\ 0 & 0 & 0 & 0 & 1 & 0 \\ 0 & 0 & 0 & 0 & 0 & 1 \end{bmatrix}, \quad i = 1, 2. \quad (2.9)$$

where:

$$b_1^{(i)} = \alpha E_i [\eta_1 E_i (1 - \nu_2^2) + \eta_2 E_2 (1 - \nu_1 \nu_2)],$$

$$b_2^{(i)} = \alpha \eta_2 (\nu_1 - \nu_2) E_i E_2,$$

$$b_3^{(i)} = \alpha \eta_2 (\nu_1 E_2 - \nu_2 E_i) [\eta_1 E_i (1 + \nu_2) + \eta_2 E_2 (1 + \nu_1)],$$

$$b_4^{(i)} = G_i / (\eta_1 G_1 + \eta_2 G_2),$$

$$b_1^{(2)} = \frac{1}{\eta_2} \{1 - \alpha \eta_1 E_i [\eta_1 E_i (1 - \nu_2^2) + \eta_2 E_2 (1 - \nu_1 \nu_2)]\},$$

$$\begin{aligned}
 b_2^{(2)} &= -\alpha\eta_1(\nu_1 - \nu_2)E_1E_2, \\
 b_3^{(2)} &= -\alpha\eta_1(\nu_1E_2 - \nu_2E_1)[\eta_1E_1(1 + \nu_2) + \eta_2E_2(1 + \nu_1)], \\
 b_4^{(2)} &= G_2/(\eta_1G_1 + \eta_2G_2), \\
 \alpha &= [\eta_1^2E_1^2(1 - \nu_2^2) + \eta_2^2E_2^2(1 - \nu_1^2) + 2\eta_1\eta_2E_1E_2(1 - \nu_1\nu_2)]^{-1}
 \end{aligned}$$

Here, E_i , ν_i , G_i denote the Young modulus, the Poisson ratio and the shear modulus respectively for the i -th component.

The matrices (2.9) will play an important role in further considerations.

2.3. Initial yield condition

The structural relation (2.5) may be treated as an affine transformation from the space of macrostresses into the space of microstresses. It is known that under an affine transformation a hypersurface is transformed into another hypersurface, and these surfaces are said to be affinely equivalent. Let:

$$f^{(i)}(\boldsymbol{\sigma}^{(i)}) = 0 \quad (2.10)$$

denotes the yield condition for the i -th component. This yield condition may be interpreted as a hypersurface in a respective space of microstresses. Under the transformation (2.5) the hypersurface (2.10) is transformed into an affinely equivalent hypersurface:

$$\bar{f}^{(i)}(\boldsymbol{\sigma}) = 0 \quad (2.11)$$

defined in the space of macrostresses. The stress states satisfying the relation:

$$\bar{f}^{(i)}(\boldsymbol{\sigma}) < 0 \quad (2.12)$$

represent the range of the elastic behaviour for the i -th constituent.

Let $\bar{F}^{(i)}$ denotes interior of the space bounded by the hypersurface (2.11). The common part of two regions

$$\bar{F} = \bar{F}^{(1)} \cap \bar{F}^{(2)} \quad (2.13)$$

represent macrostress states corresponding to the elastic behaviour of both constituents of the composite, so that the structural relations (2.5) are valid:

$$\bigwedge_{\boldsymbol{\sigma} \in \bar{F}} \boldsymbol{\sigma}^{(i)} = \mathbf{B}^{(i)}\boldsymbol{\sigma}. \quad (2.14)$$

Let:

$$\bar{f}(\boldsymbol{\sigma}) = 0 \quad (2.15)$$

denotes the hypersurface bounding the region \bar{F} . The relation (2.12) is fulfilled in this region for both constituents. In general, the hypersurface (2.15) may be composed of pieces corresponding to the plastic state of particular constituents. The relation (2.15) will be called the initial yield condition. Further, the stress states satisfying the initial yield condition will be distinguished, for clarity, by a star.

2.4. One of the constituents becomes plastic

When the initial yield condition (2.15) is attained, one of the components, alternatively both of them, becomes plastic. If the process of further loading proceeds, i.e. the macrostress vector passes through the hypersurface (2.15), the structural relations (2.5) do not hold.

Let it be assumed that the initial yield condition is attained on the yield surface corresponding to the 1-st component, i.e.:

$$\bar{f}^{(1)}(\sigma^*) = 0. \quad (2.16)$$

Let $d\sigma$ denotes the macrostress increment, such that:

$$\sigma = \sigma^* + d\sigma, \quad (2.17)$$

where σ^* satisfies the initial yield condition (2.16). If $d\sigma$ is directed into the interior of the initial yield surface the process of unloading takes place. If $d\sigma$ is tangent to the initial yield surface the regrouping of elastic states in both components may appear. The component being in an elastic state imposes the constrains on a plastic flow of the 1-st component. However, in some cases there are no constrains and the plastic flow of the first component is possible, as for example for the pure shear discussed in Section 4.

The stress increment $d\sigma$ outward to the initial yield surface may be directed arbitrarily. In general, the regrouping of elastic states in both constituents appears and the vector $\sigma^{(1)}$ glides on the surface $f^{(1)} = 0$. The composite behaves macroscopically as a material with hardening.

Let us consider the particular form of $d\sigma$, such which prevent the vector σ^* from gliding at the initial yield surface. Such forms of the macrostress increment $d\sigma$ will be discussed in detail in the next sections. In these cases the structural relations (2.5) do not hold. The macrostress increment $d\sigma$, which does not cause the gliding of the vector σ^* at the initial yield surface, is taken over by the constituent being in an elastic state, i.e.:

$$d\sigma^{(2)} = \frac{1}{\eta_2} d\sigma. \quad (2.18)$$

The microstress increment (2.18) causes in the 2-nd component the following increment of the microstrain vector:

$$d\epsilon^{(2)el} = M^{(2)} d\sigma^{(2)} = \frac{1}{\eta_2} M^{(2)} d\sigma, \quad (2.19)$$

where $M^{(2)}$ denotes the matrix of elastic compliances for the 2-nd constituent.

As it was previously mentioned, the associated flow rule is assumed to be valid for both constituents:

$$d\epsilon^{(i)pl} = d\lambda^{(i)} \frac{\partial f^{(i)}}{\partial \sigma^{(i)}}. \quad (2.20)$$

The r.h.s. of relation (2.20) transforms into the space of macrostresses according to the law:

$$\frac{\partial \bar{f}^{(i)}}{\partial \sigma} = B^{(i)T} \frac{\partial f^{(i)}}{\partial \sigma^{(i)}}. \quad (2.21)$$

Then, the increment of plastic microstrains in the first constituent is following:

$$d\epsilon^{(1)pl} = d\lambda^{(1)} (B^{(1)T})^{-1} \frac{\partial \bar{f}^{(1)}}{\partial \sigma}, \quad (2.22)$$

where $d\lambda^{(1)}$ is a scalar value, which will be defined later. Because the constituent in an unplastic state imposes the constrains on the plastic flow of the 1-st constituent, the strain increments (2.22) are of the same range as ones defined by relation (2.19). The internal structure of the composite imposes additional kinematical restrictions:

$$d\epsilon_{11}^{(1)pl} = d\epsilon_{11}^{(2)el}, \quad (2.23a)$$

A. SAWICKI

$$d\epsilon_{22}^{(1)pl} = d\epsilon_{22}^{(2)el}, \tag{2.23b}$$

$$d\epsilon_{12}^{(1)pl} = d\epsilon_{12}^{(2)el}. \tag{2.23c}$$

The relations (2.23) form the compatibility conditions.

2.5. Global yield condition

Let $\Delta\sigma$ denotes the finite increment of the macrostress vector. This increment will be resisted by the constituent being in as elastic state, according to the law:

$$\Delta\sigma^{(2)} = \frac{1}{\eta_2} \Delta\sigma. \tag{2.24}$$

The macrostress vector:

$$\sigma = \sigma^* + \Delta\sigma \tag{2.25}$$

causes the following microstress state in the 2-nd constituent:

$$\sigma^{(2)} = \mathbf{B}^{(2)}\sigma^* + \frac{1}{\eta_2} \Delta\sigma = \left(\mathbf{B}^{(2)} - \frac{1}{\eta_2} \mathbf{1} \right) \sigma^* + \frac{1}{\eta_2} \sigma. \tag{2.26}$$

Substitution of relation (2.26) into the yield condition for the 2-nd constituent:

$$f^{(2)}(\sigma^{(2)}) = 0 \tag{2.27}$$

gives the following:

$$\bar{f}^{(2)}(\sigma^*, \sigma) = 0, \tag{2.28}$$

where σ^* satisfies the initial yield condition (2.15). It follows, from the above considerations, that for every point lying on the initial yield surface and characterized by σ^* corresponds one surface defined by (2.28). The second constituent becomes plastic at the intersection point of the surface (2.28) by the straight line. The direction of this line is given by the vector $\Delta\sigma$. The set of these intersection points form the global yield surface. The general discussion of the presented problem is not simple and it seems better to illustrate the problem by examples, in which both constituents are assumed to obey the Huber–Mises yield condition:

$$f^{(i)} = (\sigma_{11}^{(i)} - \sigma_{22}^{(i)})^2 + (\sigma_{11}^{(i)} - \sigma_{33}^{(i)})^2 + (\sigma_{22}^{(i)} - \sigma_{33}^{(i)})^2 + 6(\sigma_{12}^{(i)2} + \sigma_{13}^{(i)2} + \sigma_{23}^{(i)2}) - 2\sigma_0^{(i)2} = 0. \tag{2.29}$$

3. AXISYMMETRICAL CASE

In the case of axial symmetry the components of the macrostress vector are following: $\sigma_{11} = \sigma_{22} = \sigma_1$, $\sigma_{33} = \sigma_3$. The matrix (2.9) reduces to the form:

$$\mathbf{B}^{(i)} = \begin{bmatrix} b_1^{(i)} + b_2^{(i)} & & b_3^{(i)} \\ \dots & \dots & \dots \\ 0 & & 1 \end{bmatrix}. \tag{3.1}$$

The Huber–Mises yield condition (2.29) has the following form in the space of macrostresses:

$$\bar{f}^{(i)} = [(b_1^{(i)} + b_2^{(i)})\sigma_1 + (b_3^{(i)} - 1)\sigma_3]^2 - \sigma_0^{(i)2} = 0. \tag{3.2}$$

The relation (3.2) represents two parallel straight lines. The transformation of the yield conditions from the spaces of microstresses into the space of macrostresses is presented in Fig.

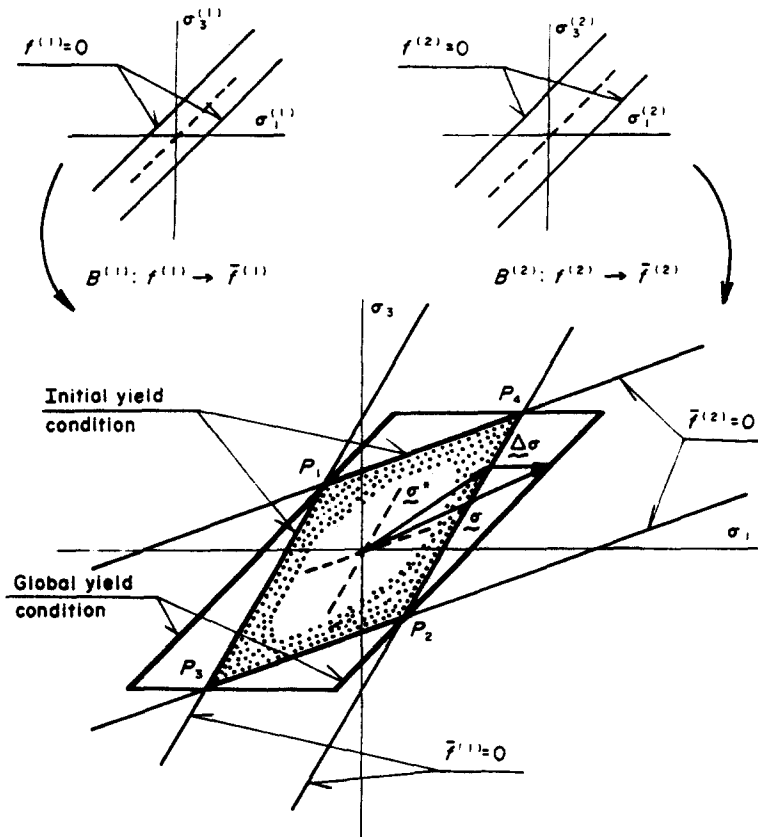

Fig. 2.

2. The dotted region presents the elastic range of composite's behaviour. Let the yield condition in the 1-st component is attained, i.e. let the relation (2.16) holds. The considered macrostress increment has the form:

$$d\sigma = d\sigma(1, 0)^T. \tag{3.3}$$

From compatibility condition (2.23a) one obtains the value of scalar function $d\lambda^{(1)}$ for an infinitesimal macrostress increment (3.3):

$$d\lambda^{(1)} = \frac{(1 - \nu_2) d\sigma}{2\eta_2 E_2 \sigma_0^{(1)}}. \tag{3.4}$$

The global yield condition (2.28) has the following form:

$$\mathcal{F} = (\sigma_1 - \sigma_3)^2 - (\eta_1 \sigma_0^{(1)} + \eta_2 \sigma_0^{(2)})^2 = 0. \tag{3.5}$$

The yield condition (3.5) does not depend on the flow rule. The illustration of the obtained result is presented in Fig. 2.

The presented approach has been applied to the problem of reinforced earth. The soil was treated as the Coulomb-Mohr material, but the reinforcement as the Huber-Mises one. The good agreement of the obtained results with the experimental data was ascertained [26].

4. PURE SHEAR

In the case of a pure shear the layered composite behaves as Reuss composite if σ_{13} or $\sigma_{23} \neq 0$ and $\sigma_{12} = 0$, or like Voigt composite if $\sigma_{12} \neq 0$ and $\sigma_{13} = \sigma_{23} = 0$, [23]. Let $\sigma_{13} \neq 0$ and the

remaining components of the macrostress vector vanish, then:

$$f^{(i)} = \bar{f}^{(i)} = \sigma_{13}^2 - \frac{1}{3}\sigma_0^{(i)2} = 0. \quad (4.1)$$

For the constituent which first becomes plastic the following relation should appear:

$$\sigma_0^{(i)} = \min\{\sigma_0^{(1)}, \sigma_0^{(2)}\}. \quad (4.2)$$

In this case the plastic flow of the composite may take place when the second constituent remains elastic.

Now, let $\sigma_{12} \neq 0$ and let remaining components of the macrostress vector vanish, then:

$$f^{(i)} = \sigma_{12}^{(i)2} - \frac{1}{3}\sigma_0^{(i)2} = 0; \quad i = 1, 2 \quad (4.3)$$

$$\bar{f}^{(i)} = \sigma_{12}^2 - \frac{1}{3}\left(\frac{\sigma_0^{(i)}}{b_4^{(i)}}\right)^2 = 0. \quad (4.4)$$

If

$$\min\left\{\frac{\sigma_0^{(1)}}{b_4^{(1)}}, \frac{\sigma_0^{(2)}}{b_4^{(2)}}\right\} = \frac{\sigma_0^{(1)}}{b_4^{(1)}} \quad (4.5)$$

then:

$$\bar{f}^{(1)} = \sigma_{12}^{*2} - \frac{1}{3}\left(\frac{\sigma_0^{(1)}}{b_4^{(1)}}\right)^2 = 0. \quad (4.6)$$

The macrostress increment will be taken over by the 2-nd constituent. Demanding the macrostress component:

$$\sigma_{12}^{(2)} = b_4^{(2)}\sigma_{12}^* + \frac{1}{\eta_2}\Delta\sigma_{12} \quad (4.7)$$

to satisfy the relation (4.3), for $i = 2$, one obtains the yield condition for the composite:

$$\mathcal{F} = \sigma_{12}^2 - \frac{1}{3}(\eta_1\sigma_0^{(1)} + \eta_2\sigma_0^{(2)})^2 = 0. \quad (4.8)$$

5. COAXIALITY OF ANISOTROPY AXES WITH THE AXES OF PRINCIPAL MACROSTRESSES

Let us consider the third case, when $\sigma_{11} = \sigma_1$, $\sigma_{22} = \sigma_2$, $\sigma_{33} = \sigma_3$, i.e. when the anisotropy axes are coaxial with the axes of principal macrostresses. The Huber-Mises yield condition (2.29) takes the following form in the space of macrostresses:

$$\bar{f}^{(i)} = \beta_1^{(i)}(\sigma_1^2 + \sigma_2^2) + \beta_2^{(i)}\sigma_3^2 + \beta_3^{(i)}\sigma_1\sigma_2 + \beta_4^{(i)}(\sigma_1\sigma_3 + \sigma_2\sigma_3) - \sigma_0^{(i)2} = 0. \quad (5.1)$$

where:

$$\begin{aligned} \beta_1^{(i)} &= b_1^{(i)}b_2^{(i)} + (b_1^{(i)} - b_2^{(i)})^2, \\ \beta_2^{(i)} &= (b_3^{(i)} - 1)^2, \\ \beta_3^{(i)} &= 2b_1^{(i)}b_2^{(i)} - (b_1^{(i)} - b_2^{(i)})^2, \\ \beta_4^{(i)} &= (b_3^{(i)} - 1)(b_1^{(i)} + b_2^{(i)}). \end{aligned}$$

The relations (5.1) present two intersecting cylinders in the space of macrostresses. Let the

yield condition in the 1-st constituent is attained. The considered macrostress increment has the form:

$$d\sigma = (d\sigma_1, d\sigma_2, 0)^T. \quad (5.2)$$

The increment (5.2) may be written in the following form:

$$d\sigma = d\sigma(1, \alpha, 0)^T, \quad (5.3)$$

where α is a parameter which will be determined from the kinematical restrictions. The elastic microstrain increment in the 2-nd constituent caused by (5.3) is following:

$$d\epsilon^{(2)el} = \frac{d\sigma}{\eta_2 E_2} \begin{pmatrix} 1 - \nu_2 \alpha \\ \alpha - \nu_2 \\ -\nu_2(1 + \alpha) \end{pmatrix}. \quad (5.4)$$

The increment of plastic strains in the 1-st constituent is as follows:

$$d\epsilon^{(1)pl} = d\lambda^{(1)} \begin{pmatrix} f_1 h_1 + f_2 h_2 \\ f_1 h_2 + f_2 h_1 \\ h_3(f_1 + f_2) + f_3 \end{pmatrix}, \quad (5.5)$$

where:

$$f_1 = 2\beta_1^{(1)}\sigma_1^* + \beta_3^{(1)}\sigma_2^* + \beta_4^{(1)}\sigma_3^*,$$

$$f_2 = 2\beta_1^{(1)}\sigma_2^* + \beta_3^{(1)}\sigma_1^* + \beta_4^{(1)}\sigma_3^*,$$

$$f_3 = 2\beta_2^{(1)}\sigma_3^* + \beta_4^{(1)}(\sigma_1^* + \sigma_2^*),$$

$$h_1 = b_1^{(1)}/(b_1^{(1)2} - b_2^{(1)2}),$$

$$h_2 = -b_2^{(1)}/(b_1^{(1)2} - b_2^{(1)2}),$$

$$h_3 = -b_3^{(1)}/(b_1^{(1)} + b_2^{(1)}).$$

The compatibility conditions (2.23a, b) are:

$$d\epsilon_1^{(2)el} = d\epsilon_1^{(1)pl}, \quad (5.6a)$$

$$d\epsilon_2^{(2)el} = d\epsilon_2^{(1)pl}. \quad (5.6b)$$

Using the relations (5.4)–(5.6) one obtains:

$$d\lambda^{(1)} = \frac{d\sigma(\alpha - \nu_2)}{f_1 h_2 + f_2 h_1}, \quad (5.7)$$

$$\alpha = \frac{f_1(h_2 + \nu_2 h_1) + f_2(h_1 + \nu_2 h_2)}{f_1(h_1 + \nu_2 h_2) + f_2(h_2 + \nu_2 h_1)}. \quad (5.8)$$

Further considerations will be restricted to the case of $\sigma_3 = 0$ for the sake of simple illustration. In this case, the yield condition (5.1) reduces to the form, for $i = 1$:

$$\bar{f}^{(1)} = \beta_1^{(1)}(\sigma_1^{*2} + \sigma_2^{*2}) + \beta_3^{(1)}\sigma_1^*\sigma_2^* - \sigma_0^{(1)2} = 0, \quad (5.9)$$

which represents on the $\sigma_1\sigma_2$ plane an ellipsis, the axes of which are turned by the angle $\pi/4$ around σ_3 axis. The yield condition (2.28) has the following form:

$$\bar{f}^{(2)} = \sigma_1^2 + \sigma_2^2 - \sigma_1\sigma_2 - \eta_1\{\sigma_1[\sigma_1^*(2b_1^{(1)} - b_2^{(1)}) + \sigma_2^*(-b_1^{(1)} + 2b_2^{(1)})] + \sigma_2[\sigma_1^*(-b_1^{(1)} + 2b_2^{(1)}) + \sigma_2^*(2b_1^{(1)} - b_2^{(1)})]\} + [(\eta_1\sigma_0^{(1)})^2 - (\eta_2\sigma_0^{(2)})^2] = 0, \quad (5.10)$$

or introducing:

$$\begin{aligned} \sigma_1 &= \Sigma_1 + \eta_1(b_1^{(1)}\sigma_1^* + b_2^{(1)}\sigma_2^*), \\ \sigma_2 &= \Sigma_2 + \eta_1(b_2^{(1)}\sigma_1^* + b_1^{(1)}\sigma_2^*) \end{aligned} \quad (5.11)$$

the more simple form:

$$\bar{f}^{(2)} = \Sigma_1^2 + \Sigma_2^2 - \Sigma_1\Sigma_2 - (\eta_2\sigma_0^{(2)})^2 = 0. \quad (5.12)$$

Then, for every point lying on the initial yield surface, and characterized by σ^* corresponds one ellipsis defined by (5.12). The second constituent becomes plastic at the intersection point of the ellipsis (5.12) and the straight line. The direction of this line is given by the vector (5.3) and its explicit form is as follows:

$$\sigma_1(X^{(1)}\sigma_1^* + Y^{(1)}\sigma_2^*) - \sigma_2(Y^{(1)}\sigma_1^* + X^{(1)}\sigma_2^*) - X^{(1)}(\sigma_1^{*2} - \sigma_2^{*2}) = 0, \quad (5.13)$$

where:

$$\begin{aligned} X^{(1)} &= 2\beta_1^{(1)}(-b_2^{(1)} + \nu_2b_1^{(1)}) + \beta_3^{(1)}(b_1^{(1)} - \nu_2b_2^{(1)}), \\ Y^{(1)} &= \beta_3^{(1)}(-b_2^{(1)} + \nu_2b_1^{(1)}) + 2\beta_1^{(1)}(b_1^{(1)} - \nu_2b_2^{(1)}). \end{aligned}$$

The equation of the global yield condition may be obtained as an envelope of the above described intersection points. This exercise is essentially simple but onerous by the analytical way. The more simple way is a numerical one. Figure 3 illustrates the above considerations for the following data: $b_1^{(1)} = 2.44754$, $b_1^{(2)} = 0.8392$, $b_2^{(1)} = b_2^{(2)} = 0$, $\eta_1 = 0.1$, $\eta_2 = 0.9$, $\sigma_0^{(1)} = 3000 \text{ kp/cm}^2$, $\sigma_0^{(2)} = 2000 \text{ kp/cm}^2$.

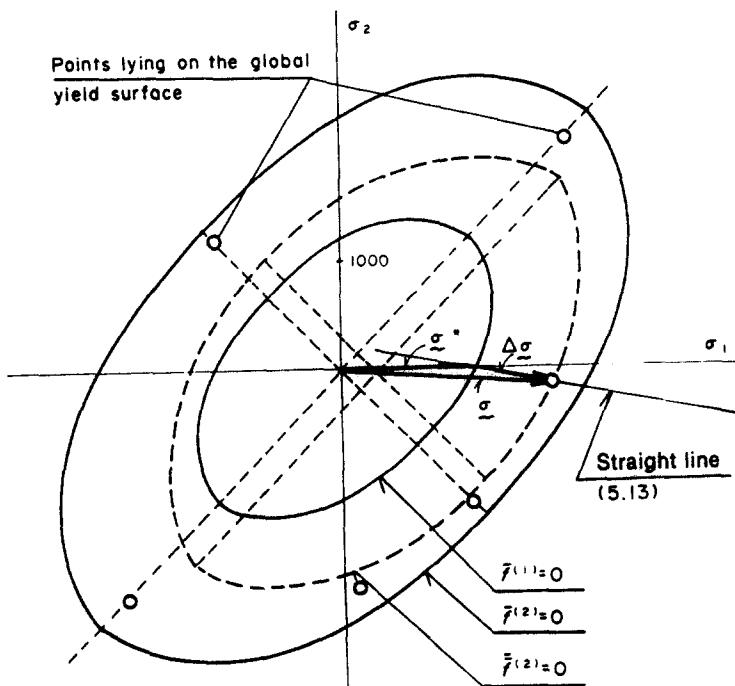

Fig. 3.

6. CONCLUSIONS

The presented theory forms a proposal of the efficient method of the elasto-plastic analysis of layered composites. The proposed approach can be applied to other types of composites [23, 24], and can be generalized to the more complicated stress states and loading paths.

There are two substantial and still open problems to be solved: the existence of the global yield surface and the problem of a flow rule for the composite.

REFERENCES

1. G. W. Postma, Wave propagation in a stratified medium. *Geophysics* XX, 780–806 (1955).
2. Z. Hashin and B. W. Rosen, The elastic moduli of fibre-reinforced materials. *Trans. ASME, J. Appl. Mech.* 31, 2, 223–232 (1964).
3. M. D. G. Salamon, Elastic moduli of a stratified rock mass. *Int. J. Rock Mech. Min. Sci.* 5, 519–527 (1968).
4. A. Sawicki, On application of effective moduli theory to layered soil. *Hydrot. Trans.* 39, 3–13 (1978).
5. C.-T. Sun, J. D. Achenbach and G. Herrmann, Continuum theory for a laminated medium. *Trans. ASME, J. Appl. Mech.* 35, 467–475 (1968).
6. G. A. Hegemier, G. A. Gurtman and A. H. Nayfeh, A continuum mixture theory of wave propagation in laminated and fibre reinforced composites. *Int. J. Solids Structures* 9, 395–414 (1973).
7. M. Stern and A. Bedford, Wave propagation in elastic laminates using a multi-continuum theory. *Acta Mechanica* XV, 21–38 (1972).
8. M. Hlaváček, On the effective moduli of elastic composite materials. *Int. J. Solids Structures* 12, 655–670 (1976).
9. Z. Hashin and S. Shtrikman, On some variational principles in anisotropic and nonhomogeneous elasticity. *J. Mech. Phys. Solids* 10, 335–342 (1962).
10. Z. Hashin and S. Shtrikman, A variational approach to the theory of the elastic behaviour of multiphase materials. *J. Mech. Phys. Solids* 11, 127–140 (1963).
11. R. Hill, Theory of mechanical properties of fibre-strengthened materials: I elastic behaviour. *J. Mech. Phys. Solids* 12, 199–212 (1964).
12. W. Prager, Plastic failure of fibre-reinforced materials. *Trans. ASME, J. Appl. Mech.* 36, 542–544 (1969).
13. A. Sawicki, Rigid-plastic theory of reinforced earth. *Arch. Hydrot.* XXVI, 419–428 (1979).
14. R. H. Lance and D. N. Robinson, A maximum shear stress theory of plastic failure of fibre-reinforced materials. *J. Mech. Phys. Solids* 19, 49–60 (1971).
15. P. V. McLaughlin, Jr. and S. C. Batterman, Limit behaviour of fibrous materials. *Int. J. Solids Structures* 6, 1357–1376 (1970).
16. P. V. McLaughlin, Jr., Plastic limit behaviour and failure of filament reinforced materials. *Int. J. Solids Structures* 8, 1299–1318 (1972).
17. J. F. Mulhern, T. G. Rogers and A. J. M. Spencer, A continuum theory of a plastic-elastic fibre-reinforced material. *Int. J. Engng Sci.* 7, 129–152 (1969).
18. V. Kafka, Structural theory of elastic-plastic deformation of unidirectional fibre-reinforced materials. Part I: The general approach. *Acta Technica ČSAV* 5, 418–436 (1973).
19. V. Kafka, Structural theory of elastic-plastic deformation of unidirectional fibre-reinforced materials. PART II: The constants of the composite. *Acta Technica ČSAV* 1, 87–95 (1974).
20. V. Kafka, On elastic-plastic deformation of composite materials with anisotropic structure. *Acta Technica ČSAV* 6, 685–706 (1976).
21. R. Hill, The essential structure of constitutive laws for metal composites and polycrystals. *J. Mech. Phys. Solids* 15, 79–95 (1967).
22. J. P. Boehler and A. Sawczuk, Application of representation theorems to describe yielding of transversely isotropic solids. *Mech. Res. Comm.* 3, 277–283 (1976).
23. A. Sawicki, Elasto-plastic theory of composites with regular internal structure. *Proc. EUROMECH 115 Coll., Mechanical Behaviour of Anisotropic Solids*, (Edited by J. P. Boehler), Villard-de-Lans, Sijthoff and Noordhoff, Amsterdam (1979).
24. A. Sawicki, Plasticity of the Voigt composites. *Bull. Acad. Polon. Sci., Sér. Sci. Techniques*, (submitted).
25. R. Hill, Elastic properties of reinforced solids: some theoretical principles. *J. Mech. Phys. Solids* 11, 357–372 (1963).
26. A. Sawicki, Généralization de la formule LCPC en cas de l'essai triaxial de compression de la terre armée. *Proc. Coll. Franco-Polonais, LCPS 71–77*, Paris (1979).